

Pilar				Fundação				Bloco		
Nome	Seção (cm)	X (cm)	Y (cm)	Carga Máx. (tf)	Lado B (cm)	Lado H (cm)	h1/hb (cm)	ne	Estaca	ca (cm)
P1	16x70	215.61	3601.34	2.2	70	70	30	60	1	D30 C=3m
P4	16x70	215.61	3236.84	2.2	70	70	30	60	1	D30 C=3m

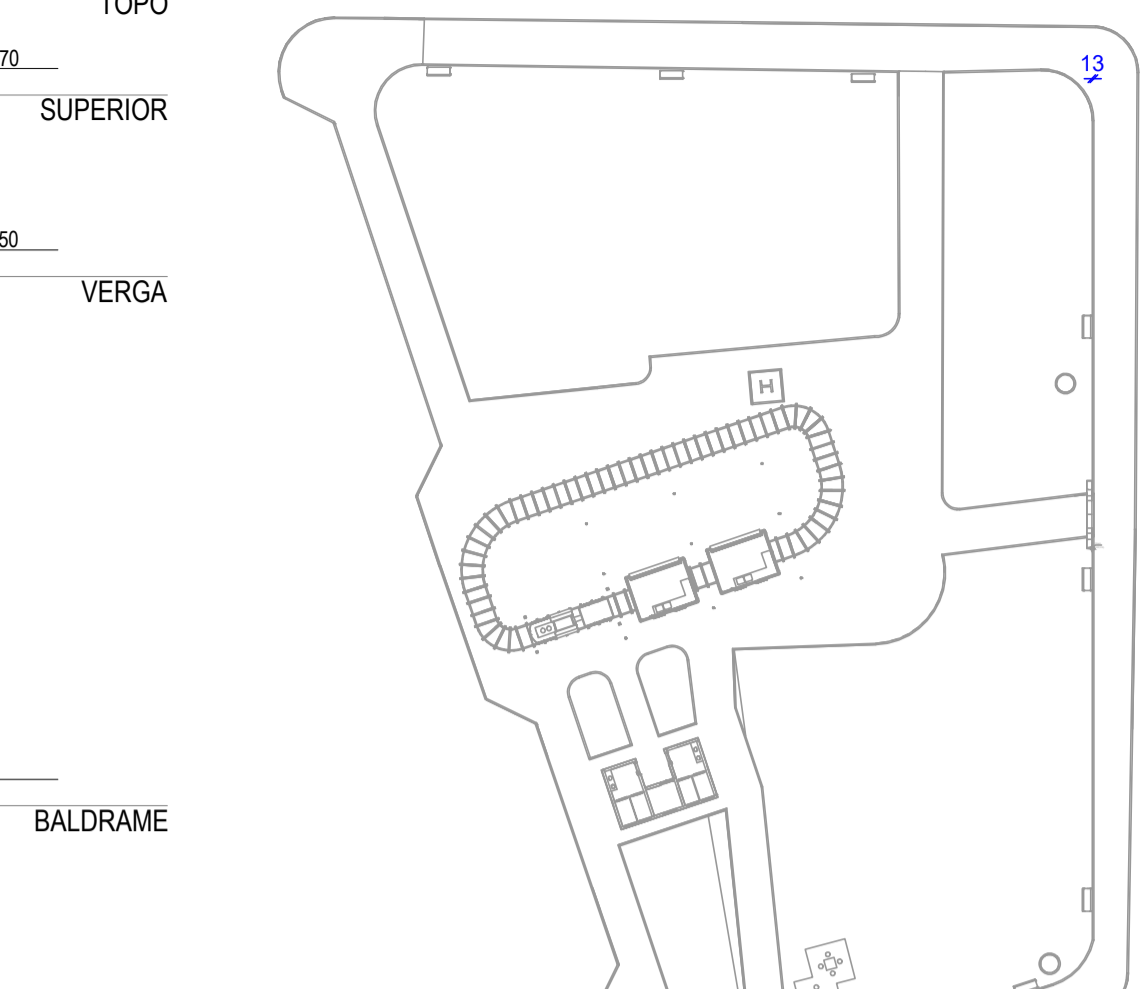
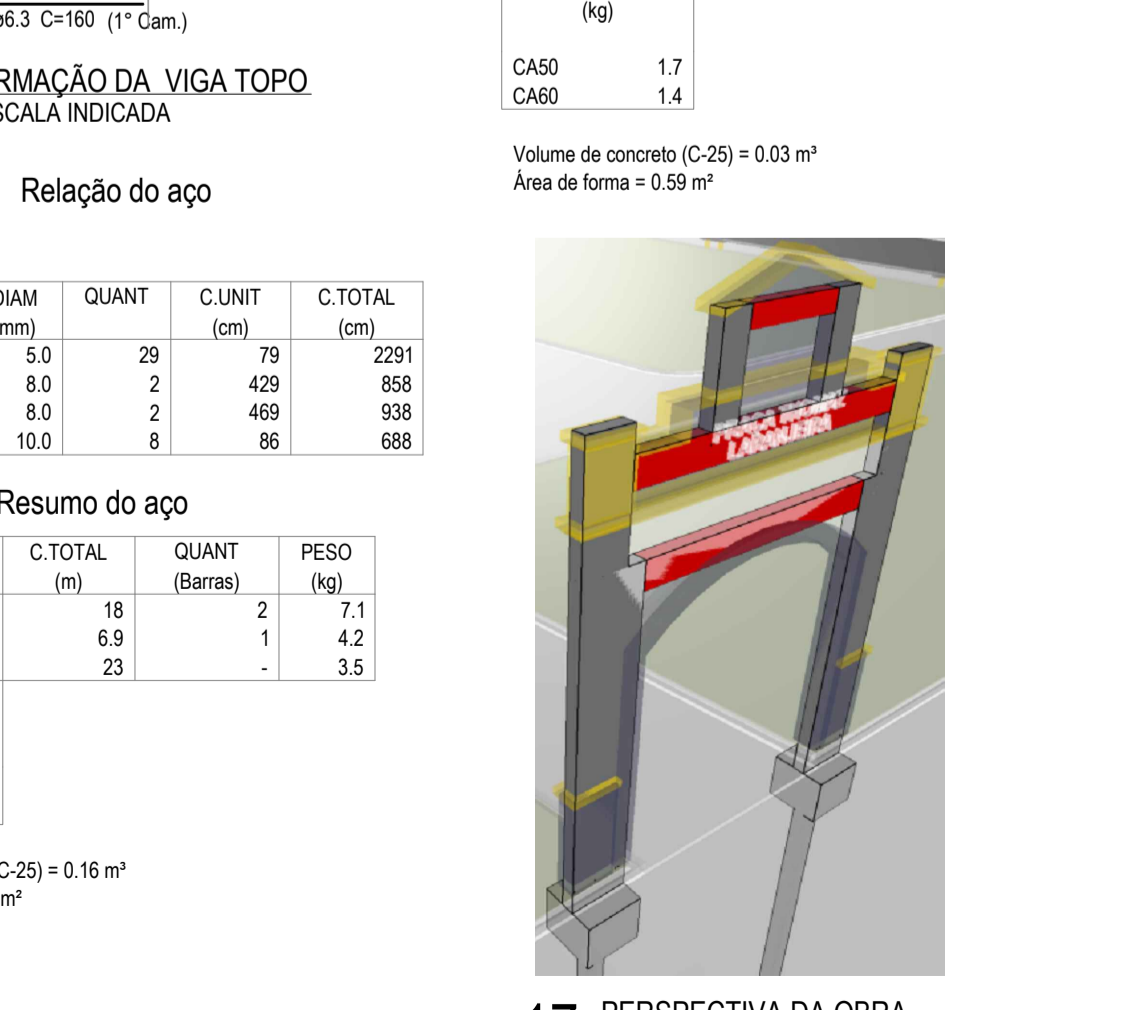
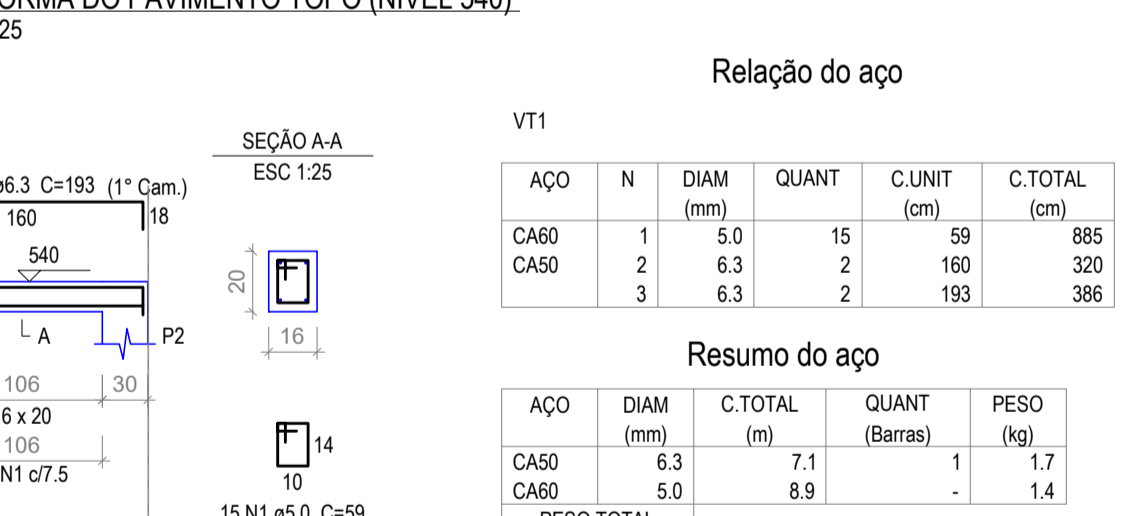
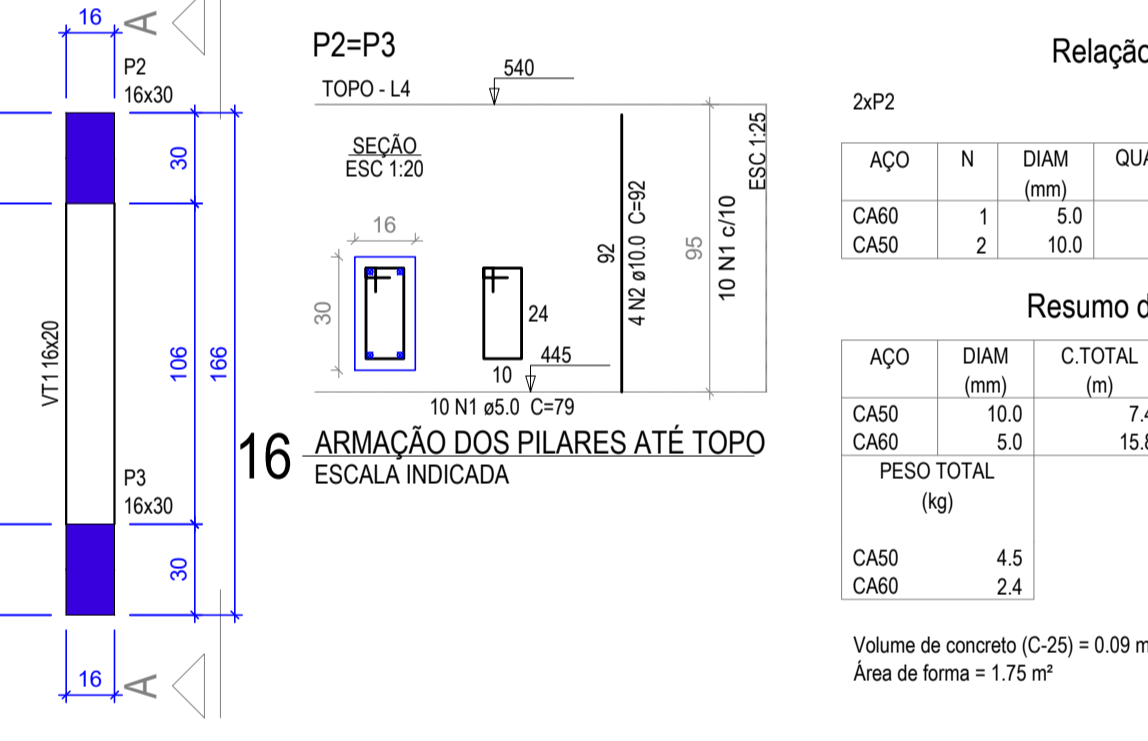
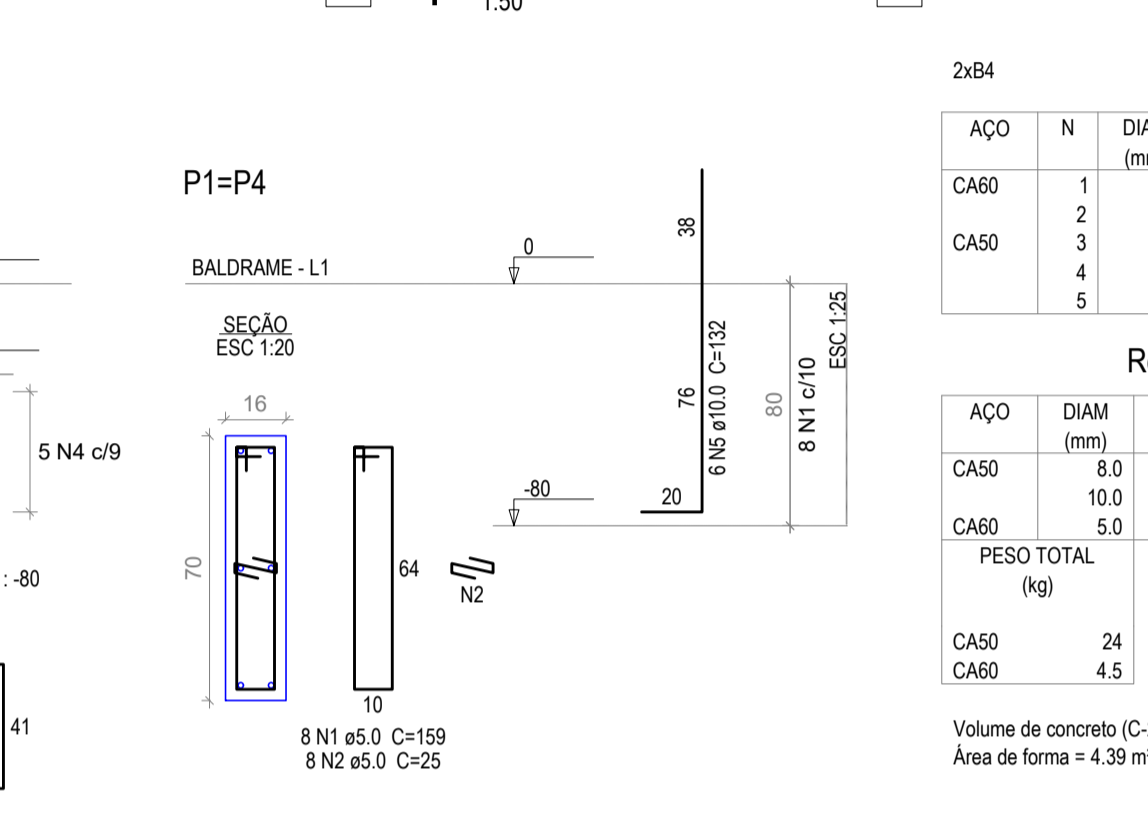
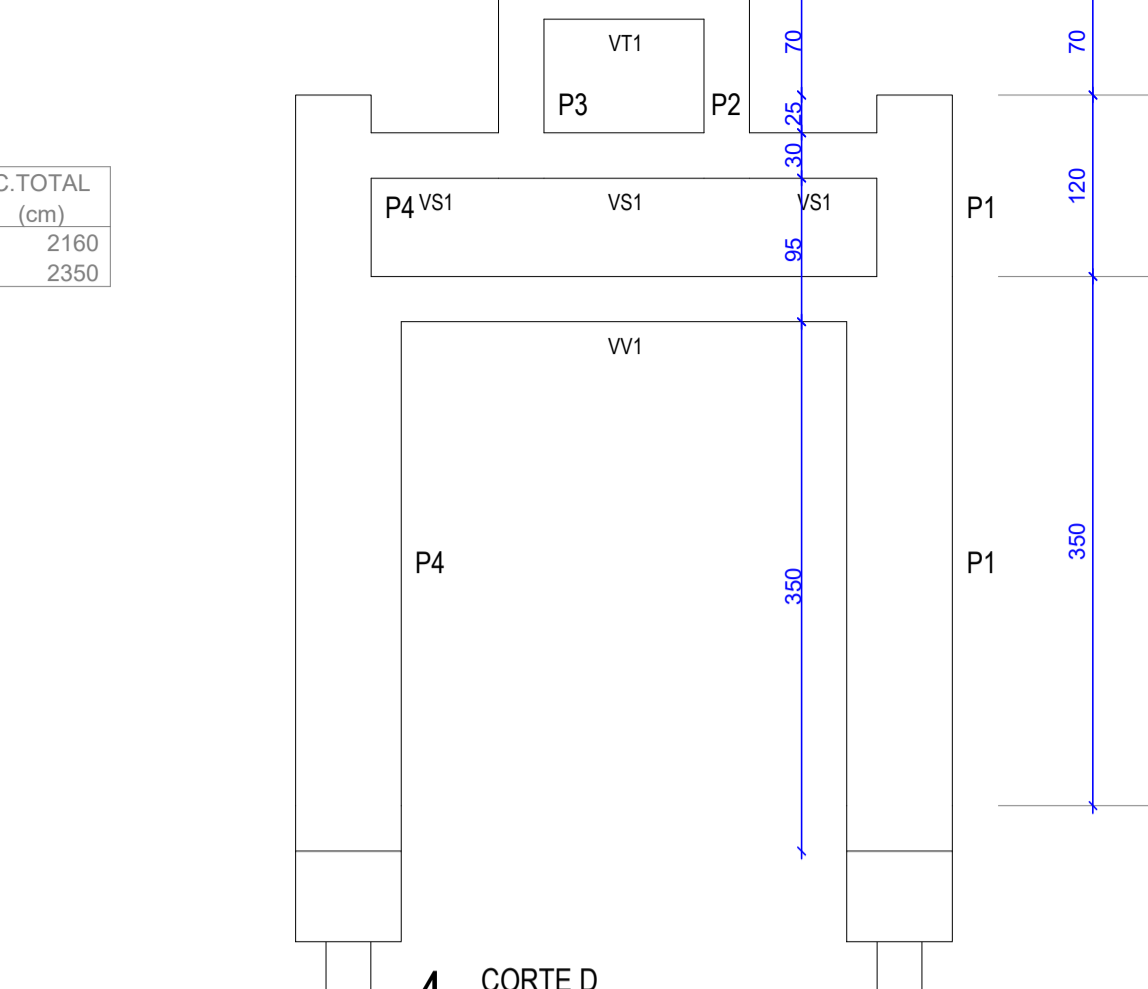
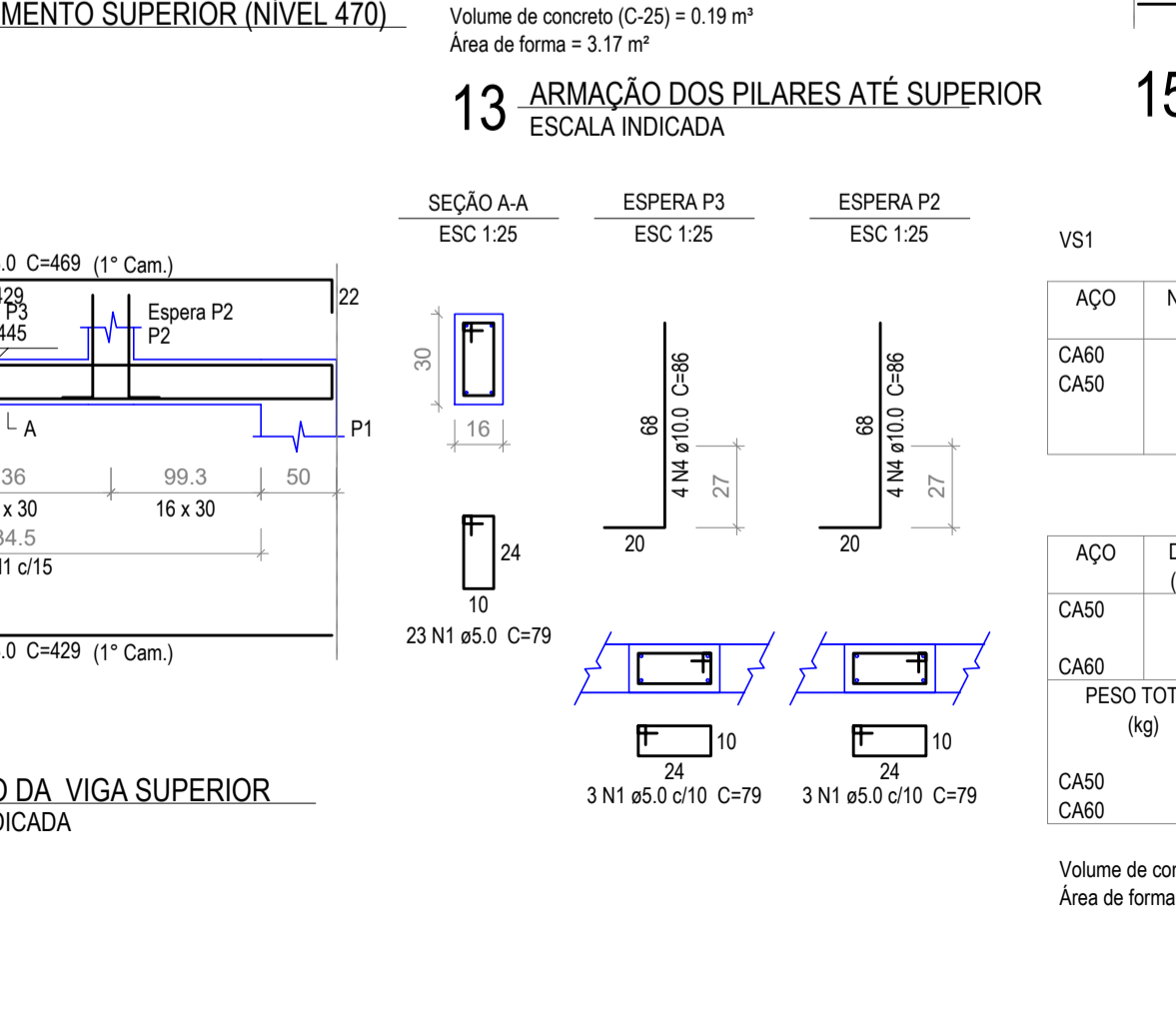
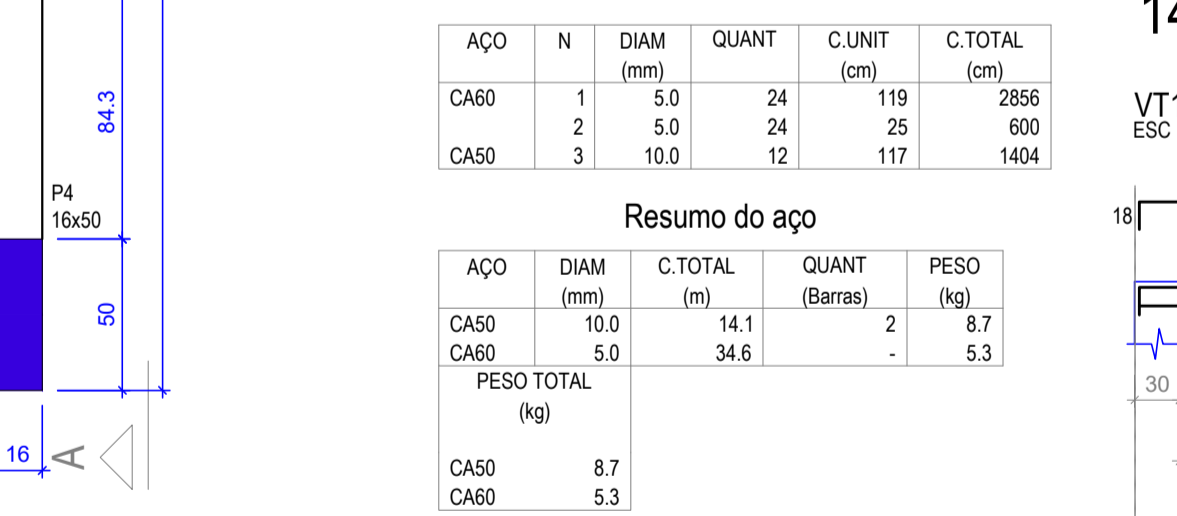
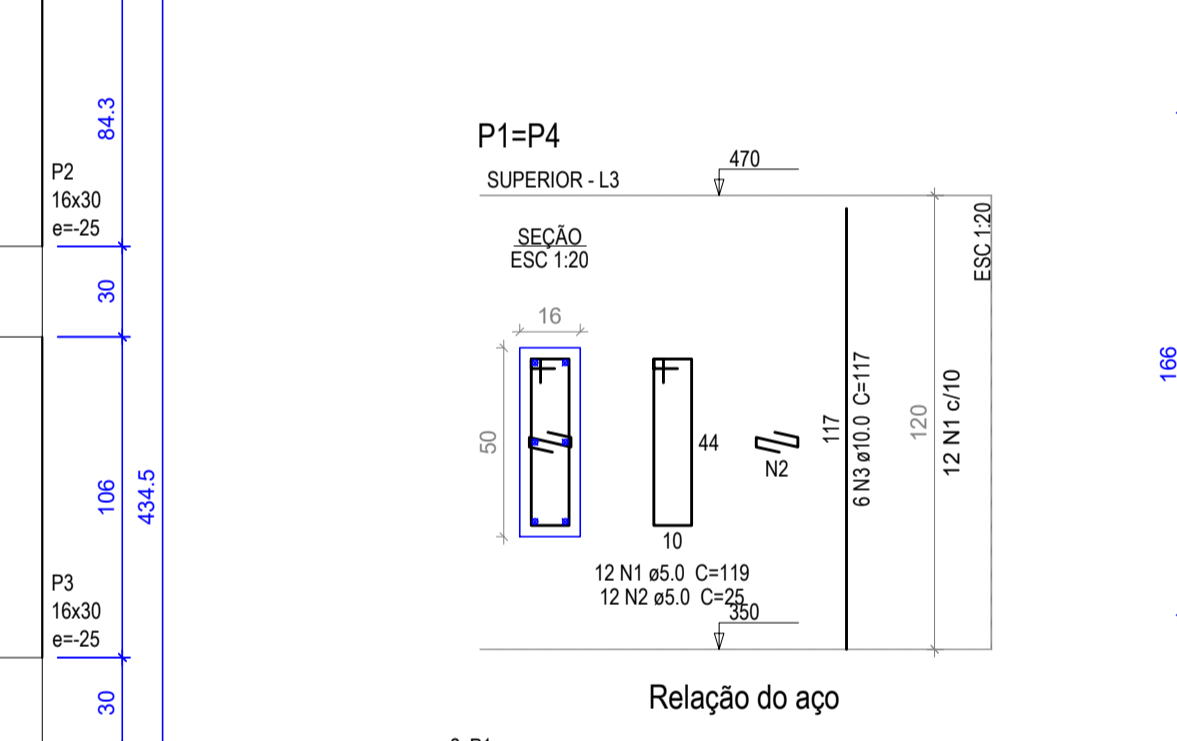
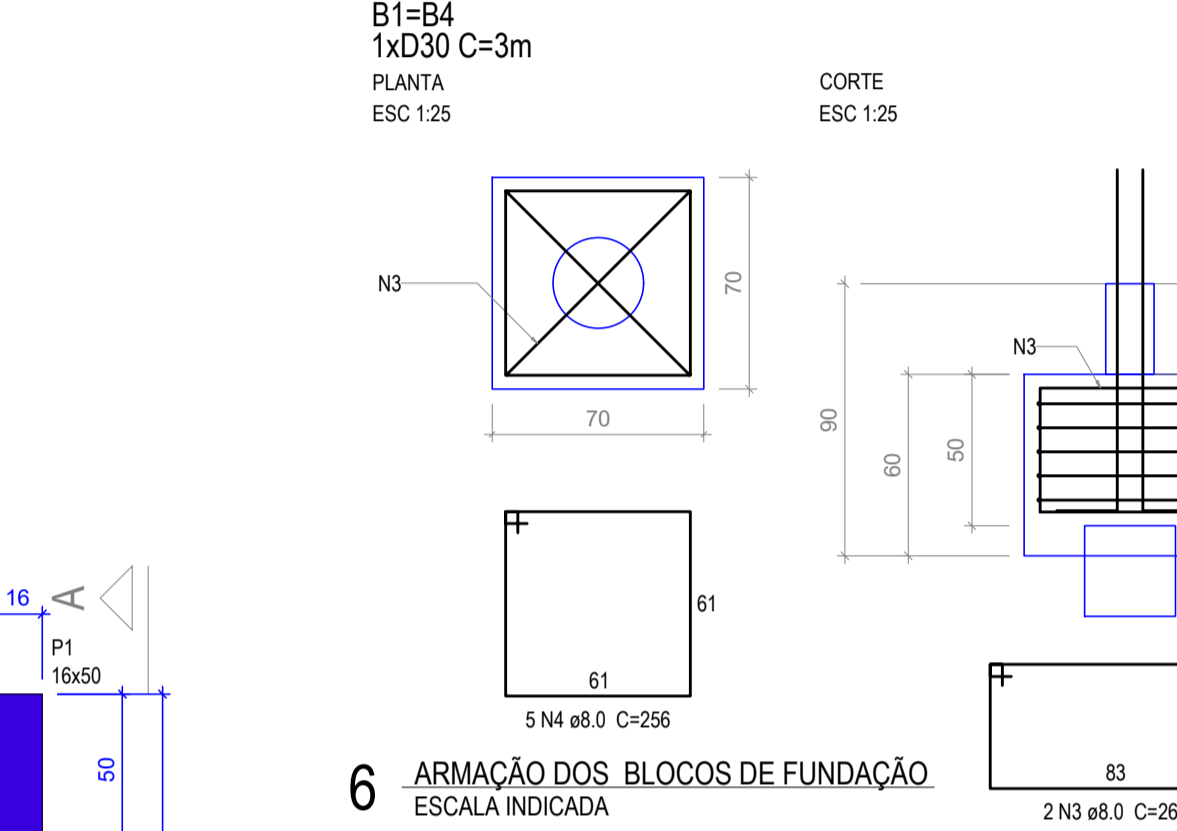
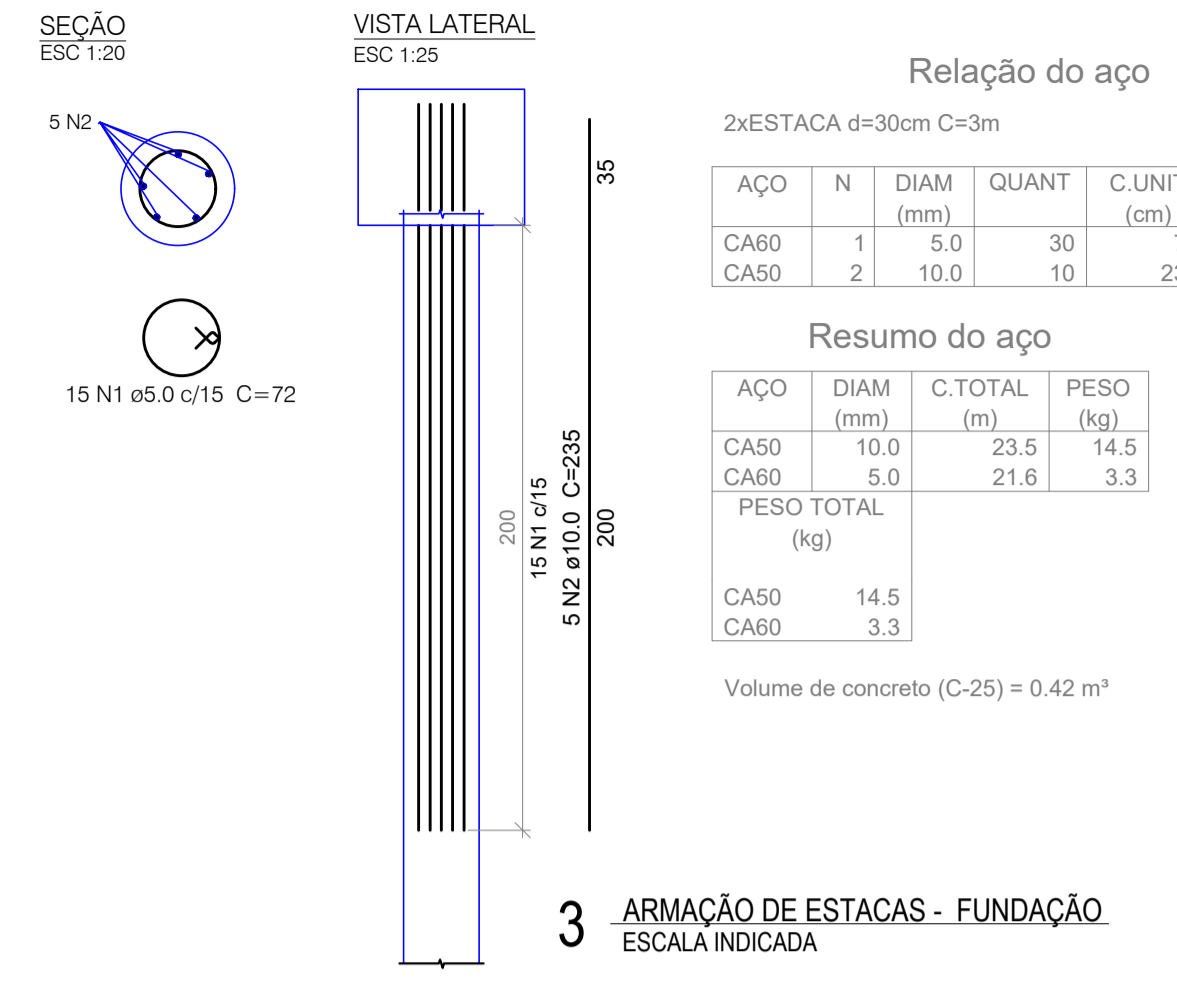
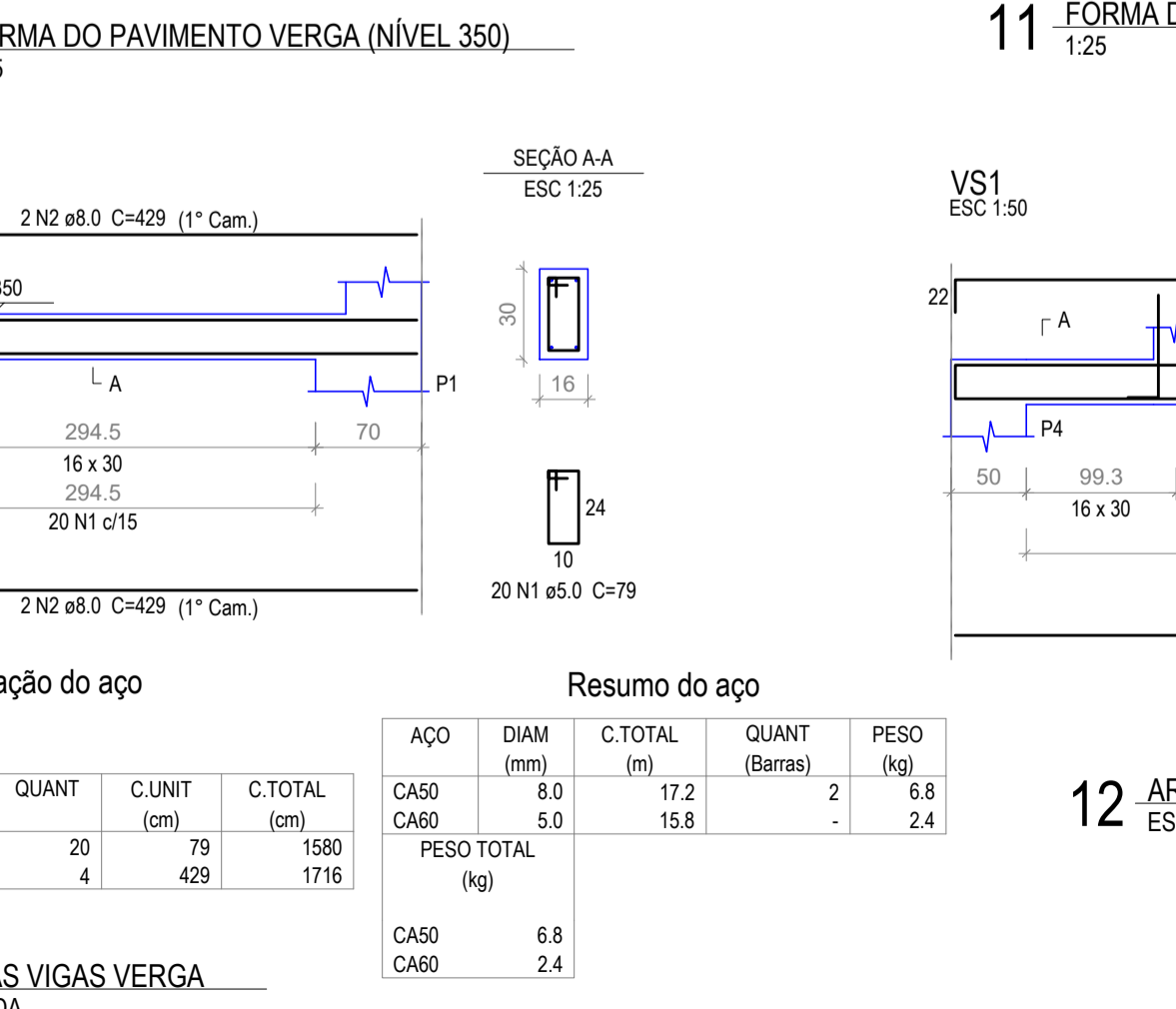
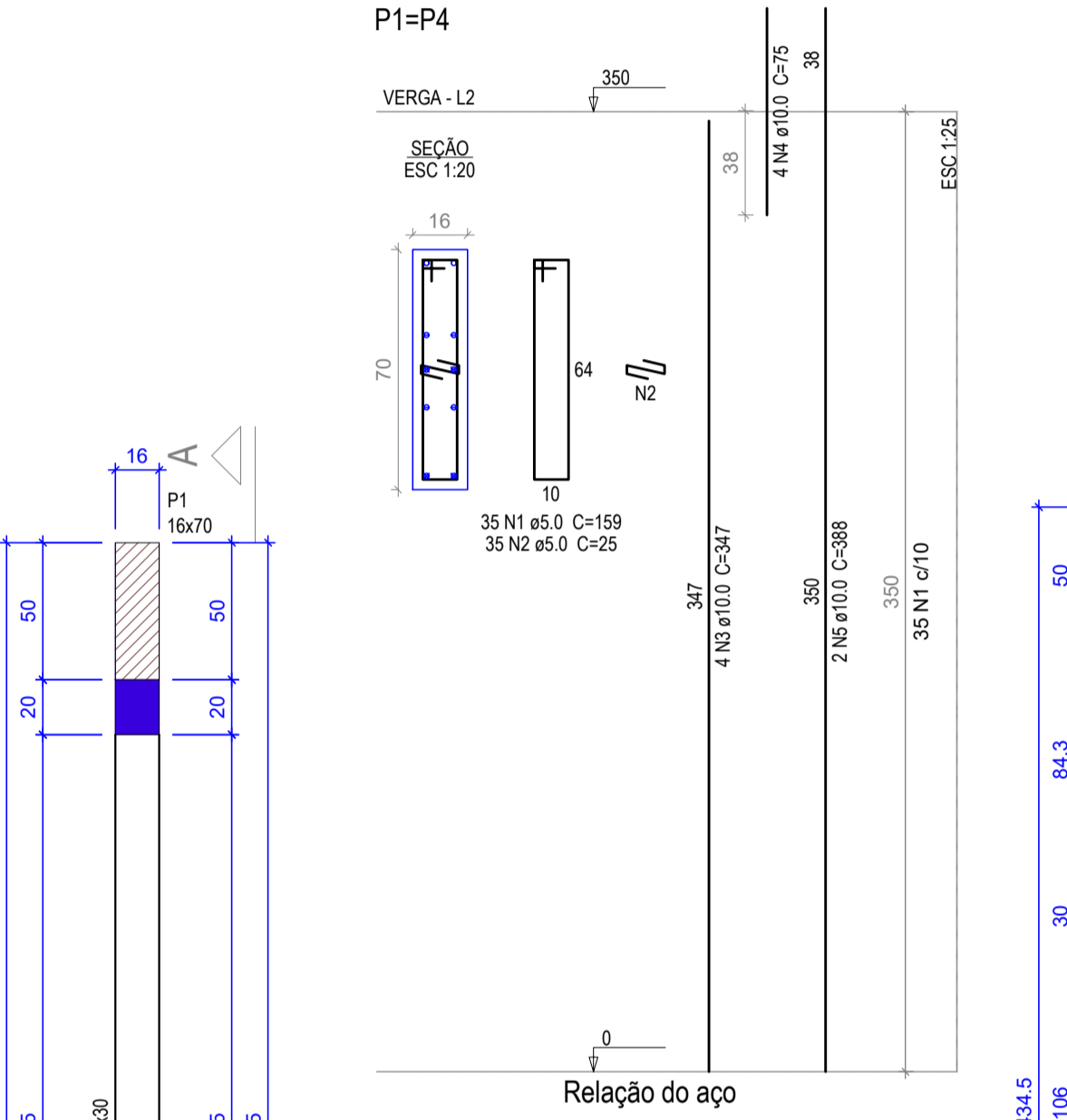

Relação do aço	AÇO	N	DIAM (mm)	QUANT	C.UNIT (cm)	C.TOTAL (cm)
2xP1	CA60	1	5.0	70	159	11130
	CA50	2	5.0	70	25	1750
	CA50	3	10.0	8	347	2776
	CA60	4	10.0	75	600	6000
	CA60	5	10.0	4	388	1552

Relação do aço	AÇO	N	DIAM (mm)	QUANT	C.UNIT (cm)	C.TOTAL (cm)
2xP2	CA60	1	5.0	16	159	2544
	CA50	2	5.0	16	25	400
	CA60	3	8.0	4	260	1040
	CA60	4	8.0	10	256	2560
	CA60	5	10.0	12	132	1584

Relação do aço	AÇO	N	DIAM (mm)	QUANT	C.UNIT (cm)	C.TOTAL (cm)
2xP3	CA60	1	5.0	16	159	2544
	CA50	2	5.0	16	25	400
	CA60	3	8.0	4	260	1040
	CA60	4	8.0	10	256	2560
	CA60	5	10.0	12	132	1584

TABELA DE REVISÃO

NÚM.	DATA	DESCRIÇÃO	REVISÃO	ALTERAÇÃO

PREFEITURA MUNICIPAL DE PORTO MURTINHO
SETOR DE APROVAÇÃO DE PROJETOS
PROJETO APROVADO

ANALISTA: _____

PREFEITURA MUNICIPAL DE PORTO MURTINHO
REVITALIZAÇÃO DA PRAÇA THOMAS LARANJEIRA NO MUNICÍPIO DE PORTO MURTINHOS

LOCAL: QUADRILÁTERO DAS RUAS DR. CORREA, TV. THOMAS LARANJEIRAS, RUA PEDRO CELESTINO E AV. LARANJEIRAS - PORTO MURTINHOS

COORDENADAS: 21°14'15" O'S, 57°53'22" O'

VISTO/CONVENIO: _____ DATA: ABRIL/2026 ÁREA CONSTRUIDA: 148,12m² ÁREA DO TERRENO: 3247,550 m²

RESPONSÁVEL TÉCNICO EM PROJETO: FÁBIO MARQUES RIBEIRO PREFEITO: NELSON CINTRA RIBEIRO

CREA nº 15.276/MS CNPJ 03.107.539/0001-32

CONTEUDO: LOCAÇÃO - PLANTAS DE FÓRMAS E ARMAÇÕES PÓRTICO DE ENTRADA

ESCALA: COMO INDICADO FOLHA: 01/01

DESENHISTA: GUSTAVO

ESTRUTURA DE CONCRETO